



# PRITIKA AUTO INDUSTRIES LTD

Regd. Office: Plot No. C-94, Phase VII, Industrial Focal Point, S.A.S. Nagar (MOHALI)-160 055  
CIN : L45208PB1980PLC046738 Tel. : 0172-5008900, 5008901

Date: 16<sup>th</sup> February, 2026

To  
Department of Corporate Services,  
National Stock Exchange of India Ltd.  
Exchange Plaza, BandraKurla Complex,  
Bandra (East), Mumbai - 400 051

To  
Department of Corporate Services,  
BSE Limited  
P.J. Towers, Dalal Street,  
Mumbai --400 001

**NSE Symbol: PRITKAUTO**

**BSE Scrip Code: 539359**

**Sub: Submission of Investor Presentation under Regulation 30 of SEBI (Listing Obligations and Disclosure Requirements) Regulations, 2015.**

Dear Sir/Madam,

With reference to Regulation 30 of the SEBI (Listing Obligations and Disclosure Requirements) Regulations, 2015, please find enclosed the Investor Presentation on the overview of the financial position and business operations of the Company for the investors and public at large.

Kindly take the same on your records and oblige.

Thanking you,

Yours truly,

For Pritika Auto Industries Limited

Chander  
Bhan Gupta

Digitally signed by  
Chander Bhan Gupta  
Date: 2026.02.16  
10:19:45 +05'30'

C B Gupta  
Company Secretary

Encl. a/a





Result update presentation Q3 & 9M FY26



**Late Raminder Singh Nibber**  
**Founder**

- **Strong Vision & Ethos laid down by our founder and first generation entrepreneur continues to guide the Company forward**
- **Mechanical Engineer started career with Escorts Limited for 10 years**
- **Awarded “UDYOG PATRA” for Self Made Industrialists by Institute of Trade and Industrial development in July 2003**
- **Ex Chairman of Confederation of Indian Industry - Mohali Zone**
- **Ex Member of Mohali Industries Association & PHD Chamber of Commerce**

*This presentation has been prepared by Pritika Auto Industries Limited (the “Company”) solely for information purposes and does not constitute any offer, recommendation or invitation to purchase or subscribe for any securities, and shall not form the basis or be relied on in connection with any contract or binding commitment what so ever. No offering of securities of the Company will be made except by means of statutory offering document containing detailed information about the Company.*

*This presentation has been prepared by the Company based on information and data which the Company considers reliable, but the Company makes no representation or warranty, express or implied, whatsoever, and no reliance shall be placed on, the truth, accuracy, completeness, fairness and reasonableness of the contents of this presentation. This presentation may not be all inclusive and may not contain all of the information that you may consider material. Any liability in respect of the contents of, or any omission from, this presentation is expressly excluded.*

*Certain matters discussed in this presentation may contain statements regarding the Company’s market opportunity and business prospects that are individually and collectively forward-looking statements. Such forward-looking statements are not guarantees of future performance and are subject to known and unknown risks, uncertainties and assumptions that are difficult to predict. These risks and uncertainties include, but are not limited to, the performance of the Indian economy and of the economies of various international markets, the performance of the industry in India and world-wide, competition, the Company’s ability to successfully implement its strategy, the Company’s future levels of growth and expansion, technological implementation, changes and advancements, changes in revenue, income or cash flows, the Company’s market preferences and its exposure to market risks, as well as other risks. The Company’s actual results, levels of activity, performance or achievements could differ materially and adversely from results expressed in or implied by this Presentation. The Company assumes no obligation to update any forward-looking information contained in this presentation. Any forward-looking statements and projections made by third parties included in this presentation are not adopted by the Company and the Company is not responsible for such third party statements and projections.*

# Table of Contents



Financial Highlights



Business Overview



Company Overview



Way Ahead



Industry Overview





Consolidated Quarterly

Financial Highlights



Commenting on the results,  
**Mr. Harpreet Singh Nibber,**  
**Chairman & Managing**  
**Director,**  
Pritika Auto Industries Limited

“This quarter’s performance has been in line with expectations, given the cyclicity in market conditions. During Q3 FY26, our consolidated revenue grew 40.64% YoY to ₹ 113.43 crore, while EBITDA increased by 37.01% to ₹ 18.34 crore and PAT by 29.43% to ₹ 5.73 crore. For 9M FY26, revenue stood at ₹ 344.48 crore, up 34.97% year-on-year, reflecting healthy demand across our key customer segments.

Looking ahead, Company is planning a strategic capital expenditure program aimed at capacity expansion, product enhancement, and operational efficiency improvements. This planned capex is expected to significantly enhance manufacturing capabilities, improve economies of scale, and support the addition of new business opportunities.

Management believes that these investments will translate into substantial revenue growth in the coming years, supported by strong customer relationships, increasing content per vehicle, and a favorable long-term outlook for the automotive and allied sectors. While the capex may have a short-term impact on margins and finance costs, it is expected to drive meaningful value creation and profitability over the medium to long term.



Company remains confident about sustaining strong growth momentum, supported by a healthy order pipeline, strong customer engagement, and focused execution of its expansion plans. Management continues to prioritize disciplined growth, cost optimization, and balance sheet strength, with a clear focus on delivering long-term value to all stakeholders. For FY26, the Company is targeting 20–25% revenue growth, driven by robust demand from existing customers, strategic entry into the Railways and the launch of new high-value products. With a sharp focus on operational efficiency, customer diversification, and enhanced capacity utilization, the Company is well positioned to deliver sustainable and profitable growth in the year ahead.

The entire team of Pritika Auto Industries limited has been instrumental in bringing us thus far and I express my sincere gratitude to all the stakeholders for their support and trust.”

# Quarterly Financial Highlights – Q3 FY26



## Standalone

### Q3 FY26

|                         |            |   |
|-------------------------|------------|---|
| ₹ 110.38 Crore          | 37.37% ↑   |    |
| Revenue from Operations | YoY Growth |   |
| ₹ 13.12 Crore           | 47.97% ↑   |    |
| 11.88%                  | YoY Growth |   |
| EBITDA & Margin         |            |   |
| ₹ 4.06 Crore            | 35.61% ↓   |  |
| 3.68%                   | YoY Growth |   |
| PAT & Margin            |            |   |

## Consolidated

### Q3 FY26

|                         |            |   |
|-------------------------|------------|---|
| ₹ 113.43 Crore          | 40.64% ↑   |    |
| Revenue from Operations | YoY Growth |   |
| ₹ 18.34 Crore           | 37.01% ↑   |    |
| 16.17%                  | YoY Growth |   |
| EBITDA & Margin         |            |   |
| ₹ 5.73 Crore            | 29.43% ↓   |  |
| 5.05%                   | YoY Growth |   |
| PAT & Margin            |            |   |

# Key Performance Indicators (Standalone)

Revenue (Rs. Cr)

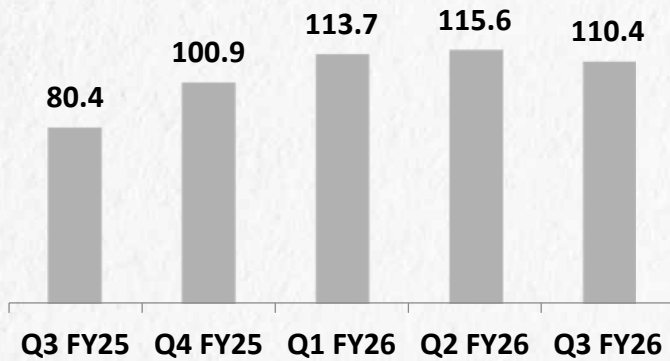

EBITDA (Rs. Cr) / Margin (%)

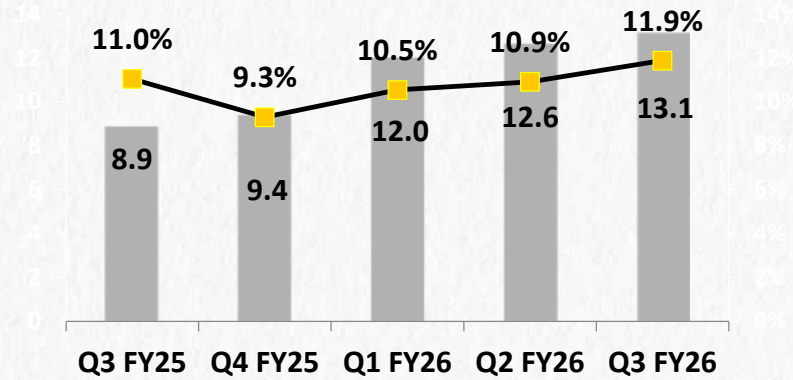

PAT (Rs. Cr) / Margin (%)

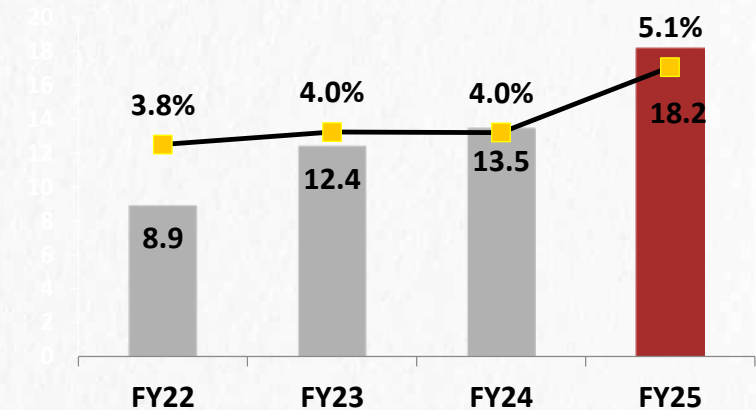
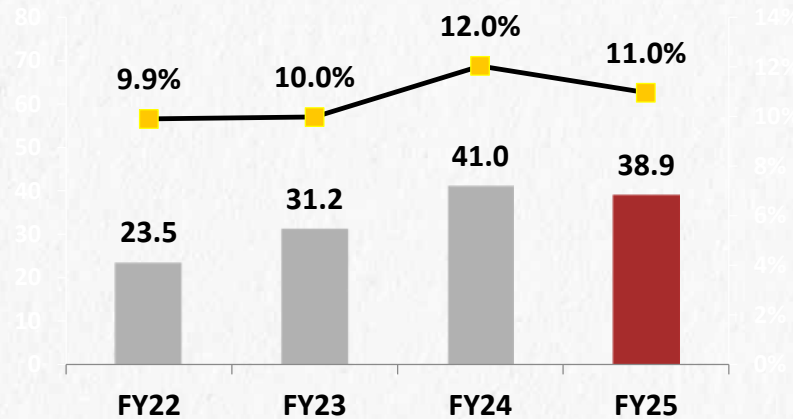
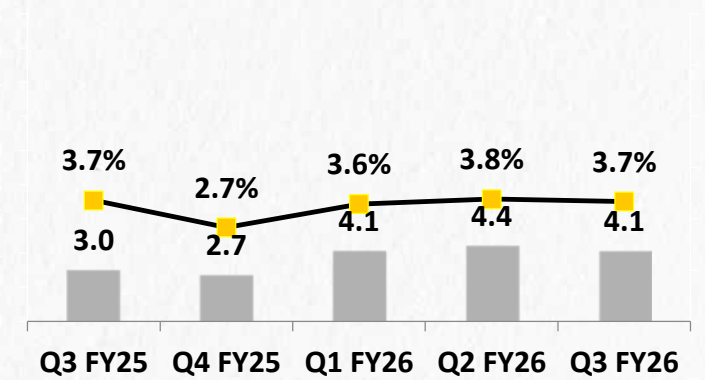

# Key Performance Indicators (Consolidated)

Revenue (Rs. Cr)

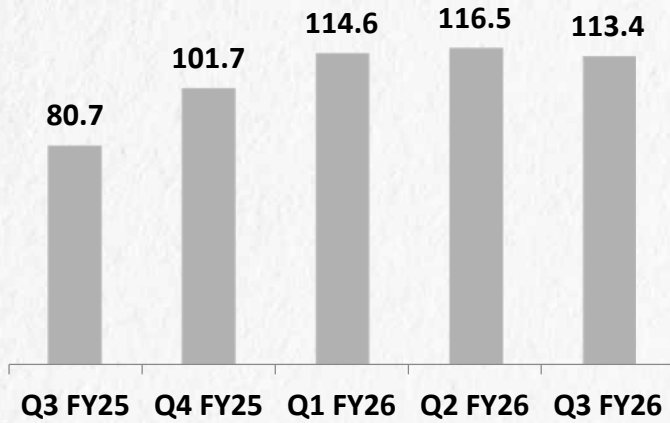

EBITDA (Rs. Cr) / Margin (%)

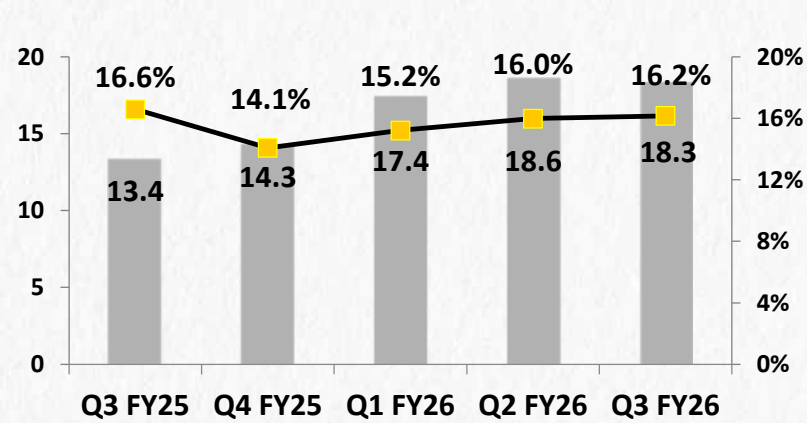

PAT (Rs. Cr) / Margin (%)

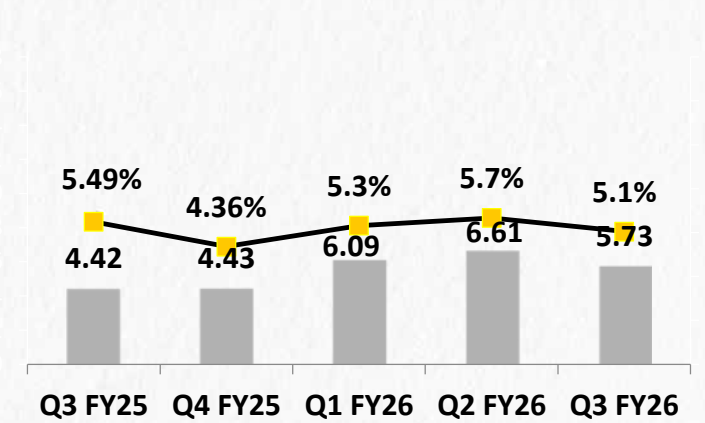

Revenue (Rs. Cr)

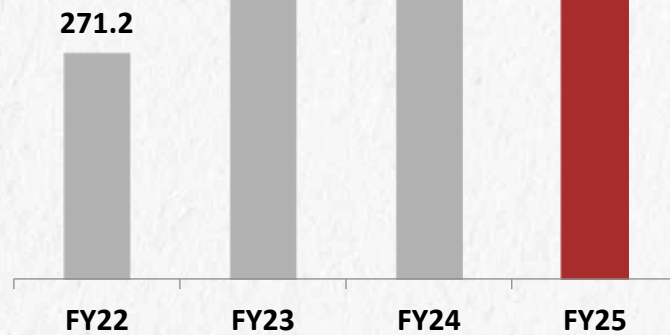

EBITDA (Rs. Cr) / Margin (%)

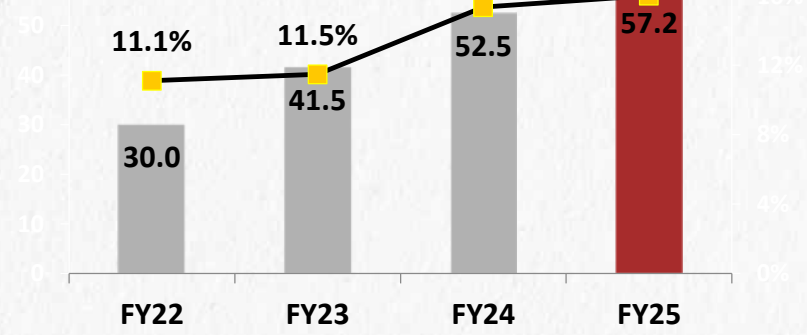

PAT (Rs. Cr) / Margin (%)

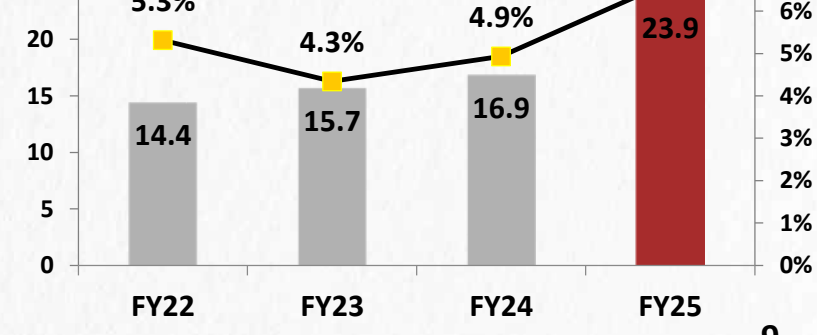

# Consolidated Financial Highlights – Quarterly

| Consolidated ( Rs. Cr)                 | Q3 FY26       | Q3 FY25       | Y-o-Y           | Q2 FY26       |
|--|---------------|---------------|-----------------|---------------|
| Total Income from operations           | <b>113.43</b> | <b>80.65</b>  |                 | <b>116.45</b> |
| Other Operating revenue                | 0.00          | 0.00          |                 | 0.00          |
| <b>Net Revenue</b>                     | <b>113.43</b> | <b>80.65</b>  | <b>40.64%</b>   | <b>116.45</b> |
| Raw Materials                          | 55.79         | 37.59         |                 | 58.80         |
| Employee Cost                          | 10.52         | 8.32          |                 | 10.45         |
| Other Cost                             | 28.79         | 21.36         |                 | 28.58         |
| <b>Total Expenditure</b>               | <b>95.09</b>  | <b>67.27</b>  | <b>41.36%</b>   | <b>97.83</b>  |
| <b>EBITDA (Excluding other income)</b> | <b>18.34</b>  | <b>13.38</b>  | <b>37.01%</b>   | <b>18.61</b>  |
| <b>EBIDTA margin (%)</b>               | <b>16.17%</b> | <b>16.59%</b> | <b>(42 bps)</b> | <b>15.99%</b> |
| Other Income                           | 0.21          | 0.43          |                 | 0.72          |
| Depreciation                           | 4.94          | 4.84          |                 | 5.12          |
| Interest                               | 5.59          | 3.61          |                 | 5.60          |
| <b>Profit Before Tax</b>               | <b>8.01</b>   | <b>5.36</b>   | <b>49.57%</b>   | <b>8.62</b>   |
| Tax                                    | 2.29          | 0.93          |                 | 2.01          |
| <b>Profit After Tax</b>                | <b>5.73</b>   | <b>4.42</b>   | <b>29.43%</b>   | <b>6.61</b>   |
| <b>PAT Margin (%)</b>                  | <b>5.05%</b>  | <b>5.49%</b>  | <b>(44 bps)</b> | <b>5.67%</b>  |
| <b>Basic EPS (Rs.)</b>                 | <b>0.31</b>   | <b>0.25</b>   | <b>24.00%</b>   | <b>0.36</b>   |

- **Net Revenue in Q3 FY26** was Rs. 113.43 crore as against Rs. 80.65 crore in Q3 FY25, YoY growth of 40.64% driven by healthy demand from key OEM customers and improved production volumes
- **EBITDA was at Rs. 18.34 crore in Q3 FY26** as against Rs. 13.38 crore in Q3 FY25, YoY growth of 37.01%, reflecting continued operating efficiency and cost discipline
- **Profit after Tax was at Rs. 5.73 crore** in Q3 FY26 as against Rs. 4.42 crore in Q3 FY25, YoY growth of 29.43%

# Consolidated Financial Highlights – Nine Months

| Consolidated ( Rs. Cr)                 | 9M FY26       | 9M FY25       | Y-o-Y            |
|--|---------------|---------------|------------------|
| Total Income from operations           | 344.48        | 255.23        |                  |
| Other Operating revenue                | 0.00          | 0.00          |                  |
| <b>Net Revenue</b>                     | <b>344.48</b> | <b>255.23</b> | <b>34.97%</b>    |
| Raw Materials                          | 174.49        | 123.73        |                  |
| Employee Cost                          | 30.52         | 24.93         |                  |
| Other Cost                             | 85.09         | 63.75         |                  |
| <b>Total Expenditure</b>               | <b>290.09</b> | <b>212.40</b> |                  |
| <b>EBITDA (Excluding other income)</b> | <b>54.39</b>  | <b>42.83</b>  | <b>27.00%</b>    |
| <b>EBIDTA margin (%)</b>               | <b>15.79%</b> | <b>16.78%</b> | <b>(99 bps)</b>  |
| Other Income                           | 1.25          | 8.42          |                  |
| Depreciation                           | 14.86         | 15.10         |                  |
| Interest                               | 16.31         | 11.29         |                  |
| <b>Profit Before Tax</b>               | <b>24.48</b>  | <b>24.86</b>  | <b>(1.55%)</b>   |
| Tax                                    | 6.05          | 5.39          |                  |
| <b>Profit After Tax</b>                | <b>18.43</b>  | <b>19.47</b>  | <b>(5.36%)</b>   |
| <b>PAT Margin (%)</b>                  | <b>5.35%</b>  | <b>7.63%</b>  | <b>(228 bps)</b> |
| <b>Basic EPS (Rs.)</b>                 | <b>1.00</b>   | <b>1.12</b>   | <b>(10.71%)</b>  |

# Consolidated Key Ratios

### RoE (%)

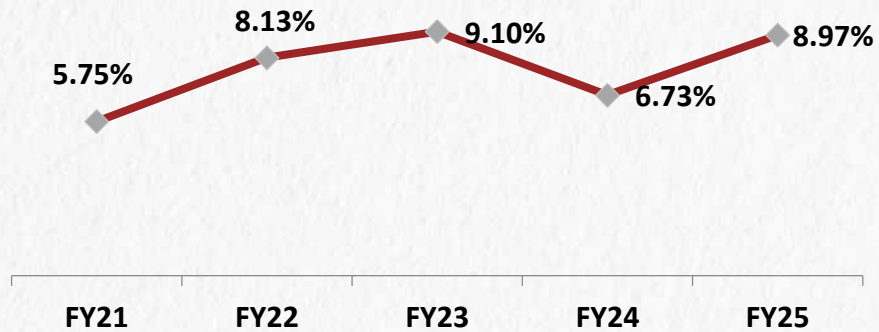

### RoA (%)

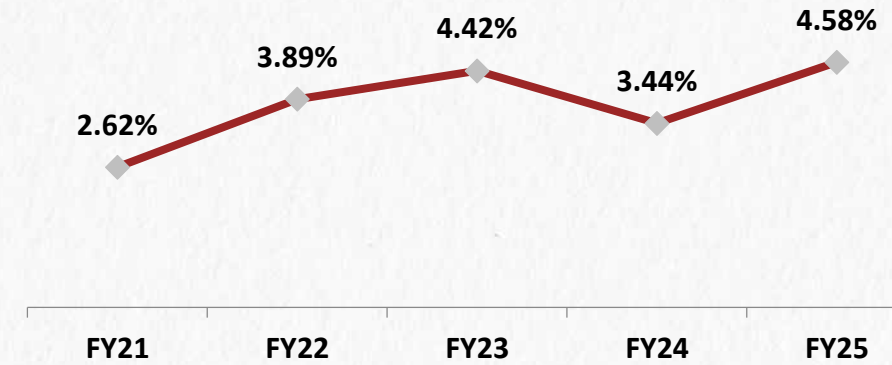

### RoCE (%)

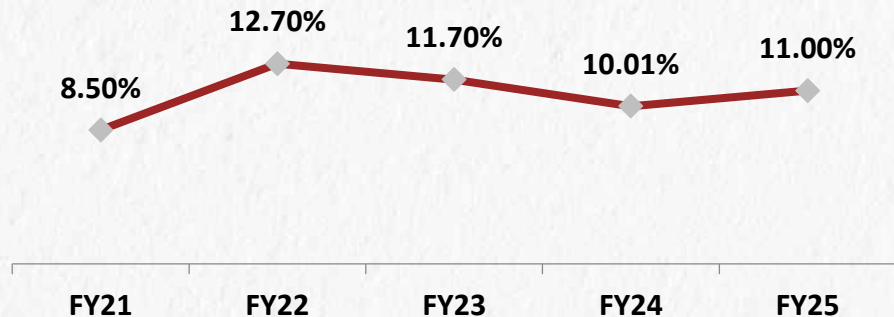

### Net Debt/Equity (x)

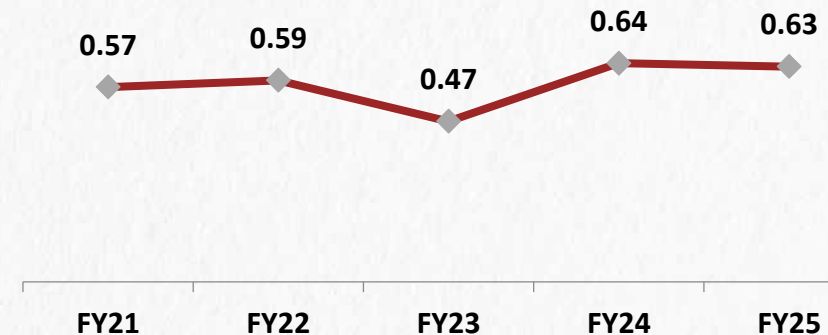



# Company Overview

---



# Company Snapshot



Amongst India's Top  
Manufacturers of  
Machined Casted  
Components



**5 Plants**  
Strategically located Plants  
in North India



Strong  
Pan India presence



**51+ years**  
Promoter's experience in  
the Industry

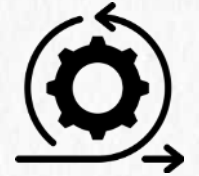

**72,000 tons**  
Installed  
Capacity Per Annum

## FY25 - Financial Metrics



**40,286**

Production Volume



₹ **356.89 Crs**

Revenue from Operations



₹ **57.15 Crs**

EBITDA  
↑ **8.90% YoY**



**11.0%**

ROCE



**9.31%**

ROE



## Vision

- To be First choice among Original Equipment's Manufacturers for Machined Castings
- To be One of the Largest Producers of Machined Castings in India

## Mission

- Installed capacity of 1,00,000 tons of Machined Castings

# About Us

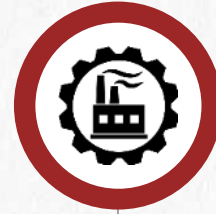
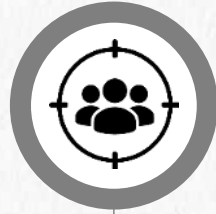

## Leading manufacturer of tractor components in India

- Incorporated in 1980
- ~5 decades of experience in Castings
- Business of manufacturing & selling of tractors and other automotive parts, components & engineering goods

## Experienced Management Team

- Significant experience in Engineering Industry
- Long term vision and proven ability to achieve long term goals for Company

## 5 Modern manufacturing facilities

- Punjab and Himachal Pradesh
- Total installed capacity:- 72,000 tons
  - **PAIL** - 42,000 MTPA
  - **PECL** – 18,000 MTPA
  - **Meeta Casting** – 12,000 MTPA

## Among biggest component suppliers in Machined Casting

- Supply to OEMs like M&M, Swaraj, TAFE, Escorts, SML Isuzu, TMTL, Ashok Leyland, New Holland Tractors India Ltd, Brakes India Ltd.

## Diversified Portfolio

- Axle Housings, Wheel Housings, Hydraulic Lift Housings, End Cover, Plate Differential Carrier, Cylinder Blocks, Crank Cases

## Long standing association with key Customers

- Escorts – 50+ years
- TAFE – 27+ years
- M&M – 19+ years

## Strong Pan India Customer presence

- Strong demand for products across key markets in India

# Journey So Far

- **1973** - Started by Mr. R. S. Nibber in 1973 as small unit of forgings for Railways
- **1975** - Started machining shop in Delhi
- **2003** - Expanded Foundry by 2,400 tons pa – Phase II
- **2003** - Total Capacity 7,800 tons pa
- **2007** - Started First integrated Foundry & Machine Shop in Village Bathri (Himachal Pradesh) with 7,800 tons pa capacity
- **2007** - Total Capacity of 15,600 tons pa
- **2015** - Expansion of capacity by 4,800 tons pa – Total 30,000 tons pa
- **2017** - Expanded capacity by 4,800 tons pa
- **2017** - Total installed capacity – 34,800 tons per annum
- **2017** - 100% booked by leading OEMs
- Expanded capacity by **4,800 tons pa**
- **Total installed capacity – 34,800 tons per annum**
- 100% booked by leading OEMs
- Addition of new client
- Successfully issued IPO for subsidiary company, Pritika Engineering Components
- Expanded capacity by 22,000 tons p.a.
- **Total installed capacity – 72,000 tons pa**
- Celebrates 50<sup>th</sup> Golden Jubilee Year
- **Received Rs. 51.5 Cr Order p.a.** from leading OEM tractor manufacturer



- **1995** - Started machine shop in Mohali
- **1997** - Started Foundry in Derabassi (Punjab) with capacity of 3000 tons pa
- **1999** - Expanded Foundry by 2,400 tons pa – Phase I
- **1999** - Total Capacity: 5,400 tons pa
- **2010** – Further capacity expansion by 4,800 tons pa – Total **20,400 tons pa**
- **2010** - 100% Booked by leading OEMs
- **2012** - Expansion of capacity by 4,800 tons pa – Total 25,200 tons pa
- **Expanded capacity by 3,200 tons pa**
- Acquired foundry capacity of 12,000 tons pa of Amrit Duraparts
- **Won first export order** for \$0.5 mn from the US, followed by repeat export order for \$1.5 mn
- Repeat order for **axle housing worth Rs. 10 cr pa**
- Demerger and vesting of “Automotive/Tractor/Engineering Components Business Undertaking” of PIL (Demerged Company) to PAIL

# Strong Management Team



**Harpreet Singh Nibber**  
Chairman & Managing Director

- Joined Pritika Group in 1996
- Second generation promoter with **29+ years** experience in Mechanical Engineering
- Specialized training in production management and business planning from AOTS, Osaka, Japan



**Narinder Kumar Tyagi**  
Director Finance & CFO

- Chartered Accountant with 34 years of experience
- Specialized in listed and unlisted companies
- Expertise span across accounts, finance, taxation and commercial matters



**Ajay Kumar Rai**  
Executive Director

- Holds Bachelor's degree in mechanical engineering and MBA in finance
- Over two decades of experience in Automotive Components and OEM Industry
- He is been key member for more than 24 years



**Navpreet S. Sujlana**  
Senior General Manager-  
Sales & Marketing

- Holds Bachelor's degree in mechanical engineering and MBA in finance
- Completed courses like language and software from NIIT, Lead Auditor Plexus India, MSA, FEMA
- He is been key member for more than 14 years

# Key Strengths



## Over five decade old strong & established Brand

Among Leading manufacturers of tractor components in India



## Diversified Product offerings

- Manufactures diverse range of products
- Continual expansion of product offerings



## Fully Integrated manufacturing set up

- Integrated operations from casting to machining
- “Ready to use” products for OEM’s



## Reputed and established Management

- Dynamic Experienced Leadership
- Vast experience in Tractor and Auto Components leads to maintain business viability & steer business through operational hurdles



## Long standing association with key Customers

- Escorts – 50+ years
- TAFE – 27+ years
- M&M – 19+ years



# Industry Overview

---



# Foundry / Casting Industry

## India Industry Overview

**2<sup>nd</sup>**

India ranks globally in casting production

**~ 5,000 Units**

Foundry Industry comprises across small, medium, and large-scale sectors

**15,00,000 Jobs**

Indirectly supporting

**\$ 5.2 bn**

Export earnings from Castings

**30 mn tons p.a.**

Industry aims to triple production over next decade

**~ 40%**

Automotive sector consumes country's castings output

**5,00,000 People**

Directly employing

**2,341 Tons p.a.**

Average productivity per unit

**\$ 12 - 15 bn**

Export earnings potential to reach within next 7-10 years

**\$ 6-8 bn**

Investment required over next 10 years

## Key Growth Drivers

**01**

Vehicle Scrap Policy to greatly benefit foundry industry

**02**

Government's 20-25% increase in load capacity per axle for goods vehicles boosts demand for heavy vehicles, benefiting foundry sector

**03**

New Manufacturing Policy aims to elevate manufacturing GDP share to 25%, underscoring foundry industry's critical role

**04**

Foundry sector invests over INR 6-8 billion to upgrade facilities and boost productivity

**05**

Government's emphasis on infrastructure projects drives demand for foundry products, fostering industry growth and development

# Indian Foundry & Tractor Industry Outlook

Indian Foundry Industry size (USD bn)

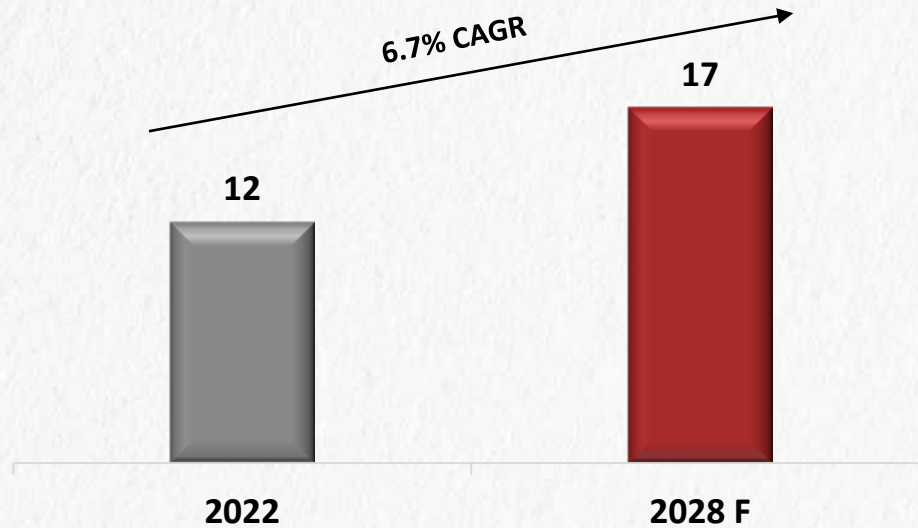

- Long-term growth expected in Earth Moving & CV Industry
- Government's increase in load capacity per axle to boost demand for castings
- Major modernization efforts in railways to boost demand in next decade
- Increasing focus on infrastructure across industries, driving demand for castings

Indian Agricultural Tractor market (USD bn)

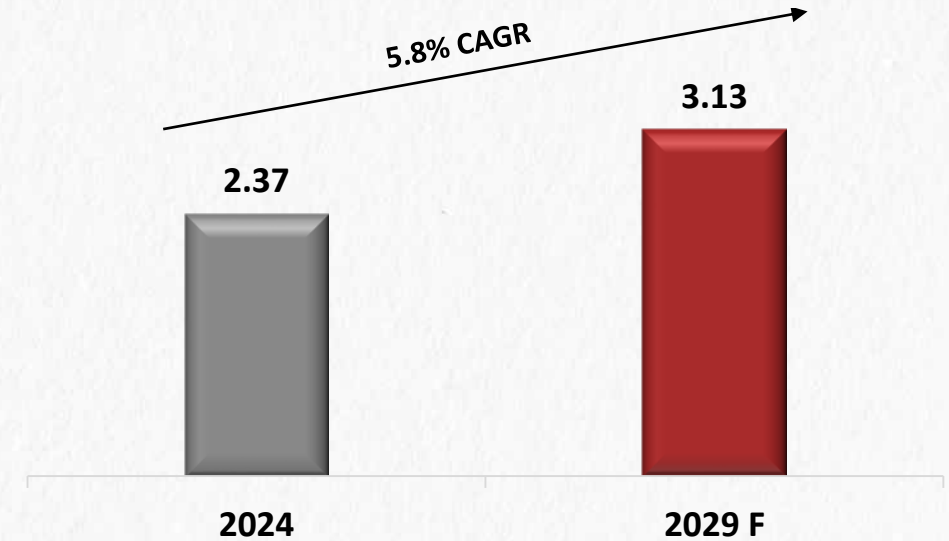

- Increased tractor demand due to good farming conditions, government support, and market factors
- India among the world's largest tractor markets, dominated by key Indian and international manufacturers
- Government subsidies and mechanization schemes driving future tractor sales growth

**With cutting-edge engineering prowess and a commitment to harnessing advanced technology, Pritika Auto Industries Limited is primed to meet burgeoning requirements of industry, paving way for substantial growth & development**

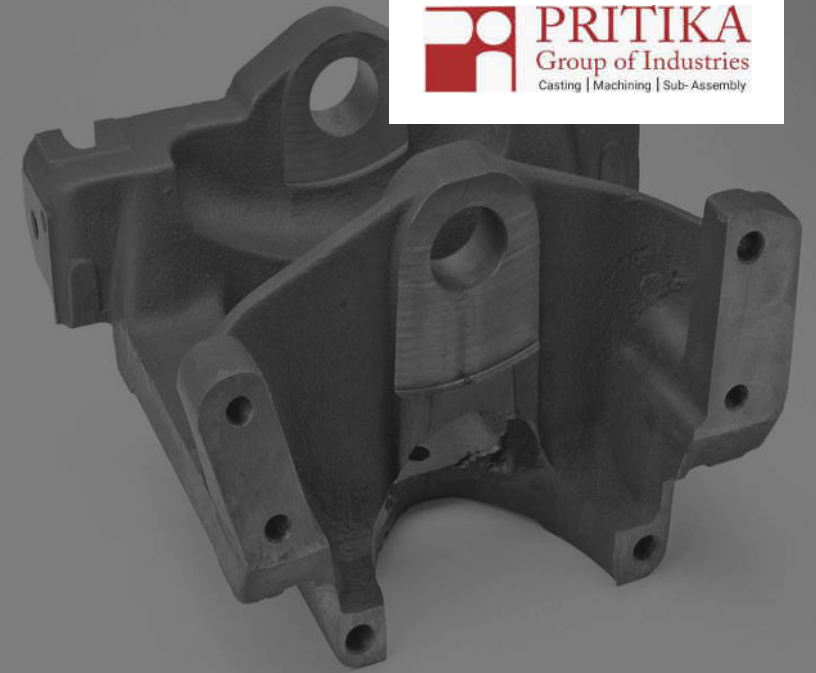
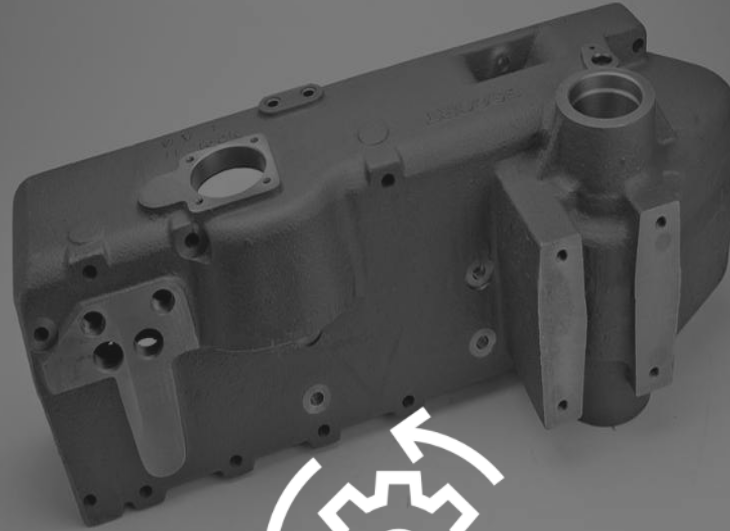
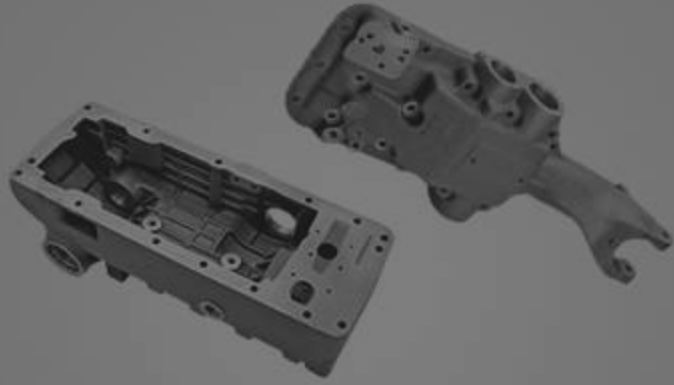

# Business Overview

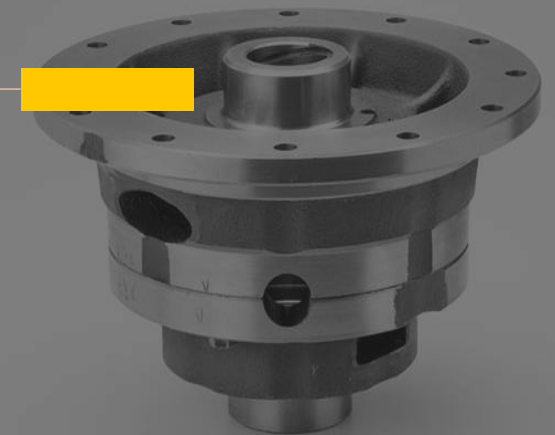
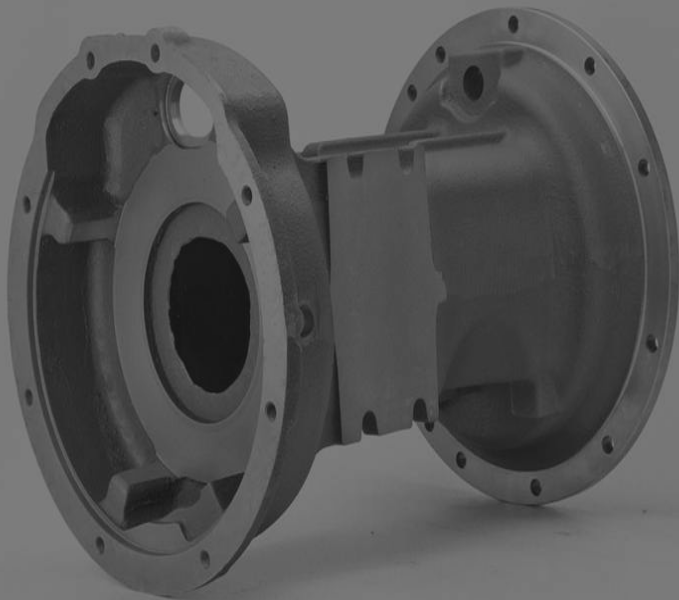

# Diversified Product Portfolio



# State of art manufacturing Facilities



**Pritika Auto Industries**  
HQ & Machine Shop

Location - Mohali, PB, India

Established - 1996

Area - 4047 sq. m

Plant Capacity in MT/Month  
1,200 MT/Month



**Pritika Auto Industries**  
Foundry

Location - Dera Bassi, PB,  
India

Established - 1997

Area – 16,187 sq. m

Plant Capacity in MT/Month  
1,500 MT/Month

Casting Material - Gray Iron



**Pritika Auto Industries**  
Foundry & Machine Shop

Location - UNA, HP, India

Established - 2006

Area – 40,470 sq. m

Plant Capacity in MT/Month  
2,000 MT/Month

Casting Material - SG,  
Gray Iron



**Pritika Engineering**  
**Components**  
Foundry & Machine Shop

Location - Simbli, PB, India

Established - 2018

Area – 28,330 sq. m

Plant Capacity in MT/Month  
1,500 MT/Month

Casting Material - SG,  
Gray Iron



**Meeta Castings**  
Lost Foam Casting Foundry

Location - Simbli, PB, India

Established - 2023

Area – 7,284 sq. m

Plant Capacity in MT/Month  
1,750 MT/Month

Casting Material - SG,  
Gray Iron

**Installed Capacity - 42,000 MTPA**

**Installed Capacity**  
**18,000 MTPA**

**Installed Capacity**  
**12,000 MTPA**

# Casting Capacity and Lines

| Plants                             | Casting Type                  | Moulding Lines |               |               |                     | LFC      | Furnaces |          |          | Plant Capacity (MT/Month) |
|------------------------------------|-------------------------------|----------------|---------------|---------------|---------------------|----------|----------|----------|----------|---------------------------|
|                                    |                               | ARPA 900 DISA  | ARPA 450 DISA | ARPA 300 DISA | HPML DISA MATCH 130 |          | 1.5 TONS | 1.0 TONS | 2.0 TONS |                           |
|                                    |                               |                |               |               |                     |          |          |          |          |                           |
| <b>PAIL-1</b>                      | Grey Iron                     | 1              | 1             | 1             |                     |          | 1        | 2        |          | 1500                      |
|                                    |                               |                |               |               |                     |          |          |          |          |                           |
| <b>PAIL-2</b>                      | Grey Iron & Ductile (Sg) Iron | 2              |               |               | 1                   |          | 2        | 5        |          | 2000                      |
|                                    |                               |                |               |               |                     |          |          |          |          |                           |
| <b>PEC</b>                         | Grey Iron & Ductile (Sg) Iron | 1              | 1             |               |                     |          | 2        | 2        |          | 1500                      |
|                                    |                               |                |               |               |                     |          |          |          |          |                           |
| <b>MC</b>                          | Grey Iron & Ductile (Sg) Iron |                |               |               |                     | 1        |          |          | 1        | 1000                      |
|                                    |                               |                |               |               |                     |          |          |          |          |                           |
| <b>PRITIKA GROUP OF INDUSTRIES</b> |                               | <b>4</b>       | <b>2</b>      | <b>1</b>      | <b>1</b>            | <b>1</b> | <b>5</b> | <b>9</b> | <b>1</b> | <b>6000</b>               |

# Strategic Location

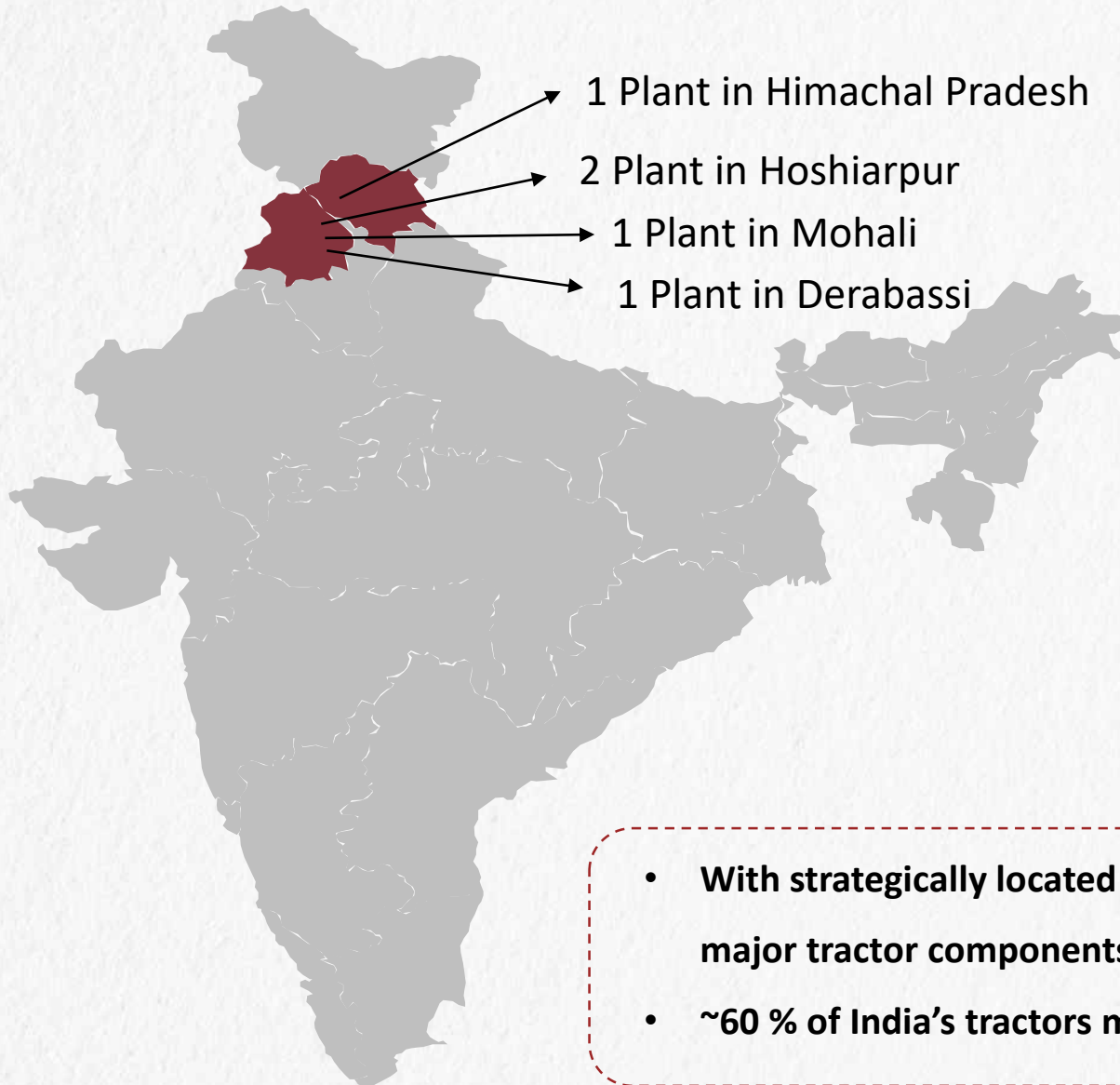

- 1 Plant in Himachal Pradesh
- 2 Plant in Hoshiarpur
- 1 Plant in Mohali
- 1 Plant in Derabassi

## Works 1 & Regd. Office

### **Pritika Auto Industries Ltd**

Plot No C 94, Phase VII, Industrial Area SAS Nagar Mohali, Punjab - 160055

## Works 2

### **Pritika Auto Industries Ltd**

Village Saido Majra,  
Near Dera Bassi Focal Point  
Dera Bassi, Distt. Mohali (Punjab)

## Works 3

### **Pritika Auto Industries Ltd**

Garshankar - Nangal Road  
Village Bathri, near Tahliwal  
District UNA (Himachal Pradesh) India

## Works 4

### **Pritika Engineering Components Ltd**

Village Simbli,  
Phagwara-Hoshiarpur Road,  
Tehsil & District Hoshiarpur, Punjab - 146001

## Works 5

### **Meeta Castings Ltd**

Village Simbli,  
Phagwara-Hoshiarpur Road, Tehsil &  
District Hoshiarpur, Punjab  
146001

- **With strategically located plants within close proximity to key OEMs, Pritika is the only major tractor components manufacturer in this region**
- **~60 % of India's tractors manufactured in this region**

# Key Customer



Swaraj Engines Limited



# Awards & Recognition



| AWARDS  | YEAR    | ORGANIZATION   |
|---|---------|--|
| Best Quality  | 2001    | CII – SIDBI India Engineering Trade Fair                         |
| 2 <sup>nd</sup> Best Display Award  | 2005    | Centre for International Trade & Industry at Made in Punjab Show |
| Best Quality Performance  | 2010-11 | Swaraj Ltd.  |
| Award For Casting Commodity   | 2012    | Mahindra & Mahindra  |
| Best Supplier   | 2012    | TAFE   |
| Best Kaizen   | 2013-14 | TAFE   |
| Star of Asia Award  | 2015    | Economic Growth Society of India                                 |
| India's Best Company of the year 2017- Best Automotive Components Manufacturing Company | 2017    | IBC Info Media Pvt. Ltd.   |
| Award for Corporate Excellence  | 2018    | Make in India Foundation (MIIF)                                  |



# Pritika Engineering Components Limited (PECL)



# About Us



***Established Player in Castings & Forgings for Tractor & Automotive OEM industry***



***Niche & Comprehensive Product Portfolio to cater wider customers***



***Long standing core customer base consisting of leading OEMs***



***Well-Invested in Lost Foam Technology to enhance the production & enhance long-term growth***

## About

- 70.81% of Pritika Engineering Components Limited is held by Pritika Auto Industries Ltd



Way Ahead

---



**01.**

## **Geographical Diversification**

- Expand in Geographically strategic locations of India
- Continue to focus on export opportunities and increase export contribution in revenues

**02.**

## **Growing Opportunity in LCV segment**

- ~7% volumes goes to LCV, we can increase our presence there

**03.**

## **New Product Development**

- Continued focus to keep adding new products in basket of products
- Develop Value Added products

**04.**

## **Export Opportunities**

- Fully equipped manufacturing facilities of global standards – to provide opportunity to global OEMs
- Incremental Capex, partially, to be dedicated towards export market

**05.**

## **Capacity Expansion**

- On course of achieving target of 1,00,00 tons installed capacity

**06.**

## **Key Focus Areas**

- Improve operational efficiencies
- Margin expansion
- Gain in Market Share



# THANK YOU

**Pritika Auto Industries Limited.**

**Ms. Nisha Saini**

EA to MD

[nisha@pritikagroup.com](mailto:nisha@pritikagroup.com)

[www.pritikagroup.com](http://www.pritikagroup.com)

**Adfactors PR**

**Mr. Amit Sharma**

[amit.sharma@adfactorspr.com](mailto:amit.sharma@adfactorspr.com)

**Mr. Rupesh Rege**

[rupesh.rege@adfactorspr.com](mailto:rupesh.rege@adfactorspr.com)

[www.adfactorspr.com](http://www.adfactorspr.com)